

DRG No
BL/D1078 INST

REMOVE ALL SHARP EDGES UNLESS SPECIFIED

THIRD ANGLE PROJECTION

DO NOT SCALE - ASK

USED ON

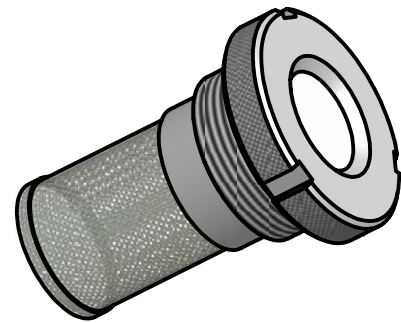

(1:2)

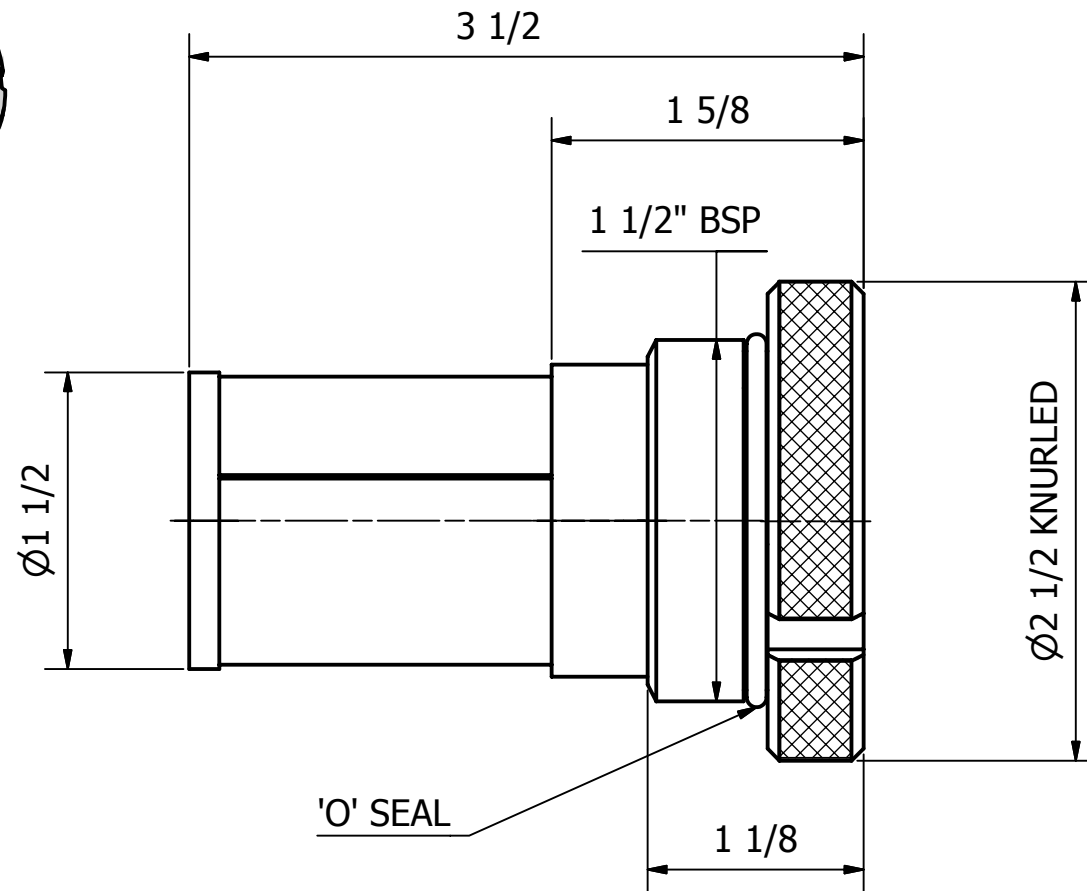

INDICATOR PAPER - 50% RH @ 20°C
BEHIND SIGHT WINDOW

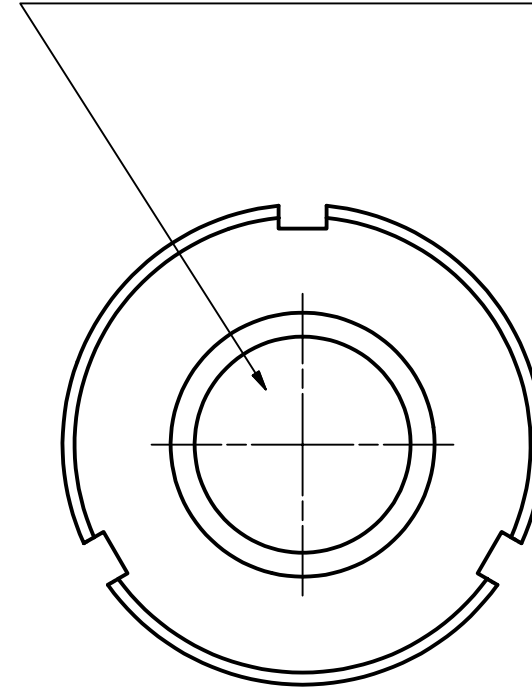

FILL WITH BEADED SILICA GEL DESICCANT

THIS DRAWING IS THE PROPERTY OF BROWNELL LTD. AND MAY NOT BE COPIED OR REPRODUCED WITHOUT THEIR PRIOR WRITTEN PERMISSION

REDRAWN	6161	2	03-08-05
CHANGE	MOD No	ISSUE	DATE

RED DOT=ORIGINAL BLACK DOT=COPY	DRAWN PK	CHECKED
------------------------------------	-------------	---------

DRAWING NUMBER
BL/D1078 INST

MATERIAL
BRASS

EST. WT. ----

PROTECTIVE FINISH
ZINC & COLOUR
PASIVAT DEF STAN
03-25

TOLERANCES	0 = ± 0.020 0.00 = ± 0.010 0.000 = ± 0.002
DIMENSIONS IN in/mm	INS
SURFACE ROUGHNESS	----
SCALE (ORIGINAL)	1:1

BROWNELL Ltd. LONDON NW10 7XF

TITLE
**DESICCANT CONTAINER
DEHUMIDIFIER PM3B**