

DRG. No.
BL/D 4967 INST
USED ON

REMOVE ALL SHARP EDGES UNLESS SPECIFIED.

THIRD ANGLE PROJECTION

DO NOT SCALE - ASK.

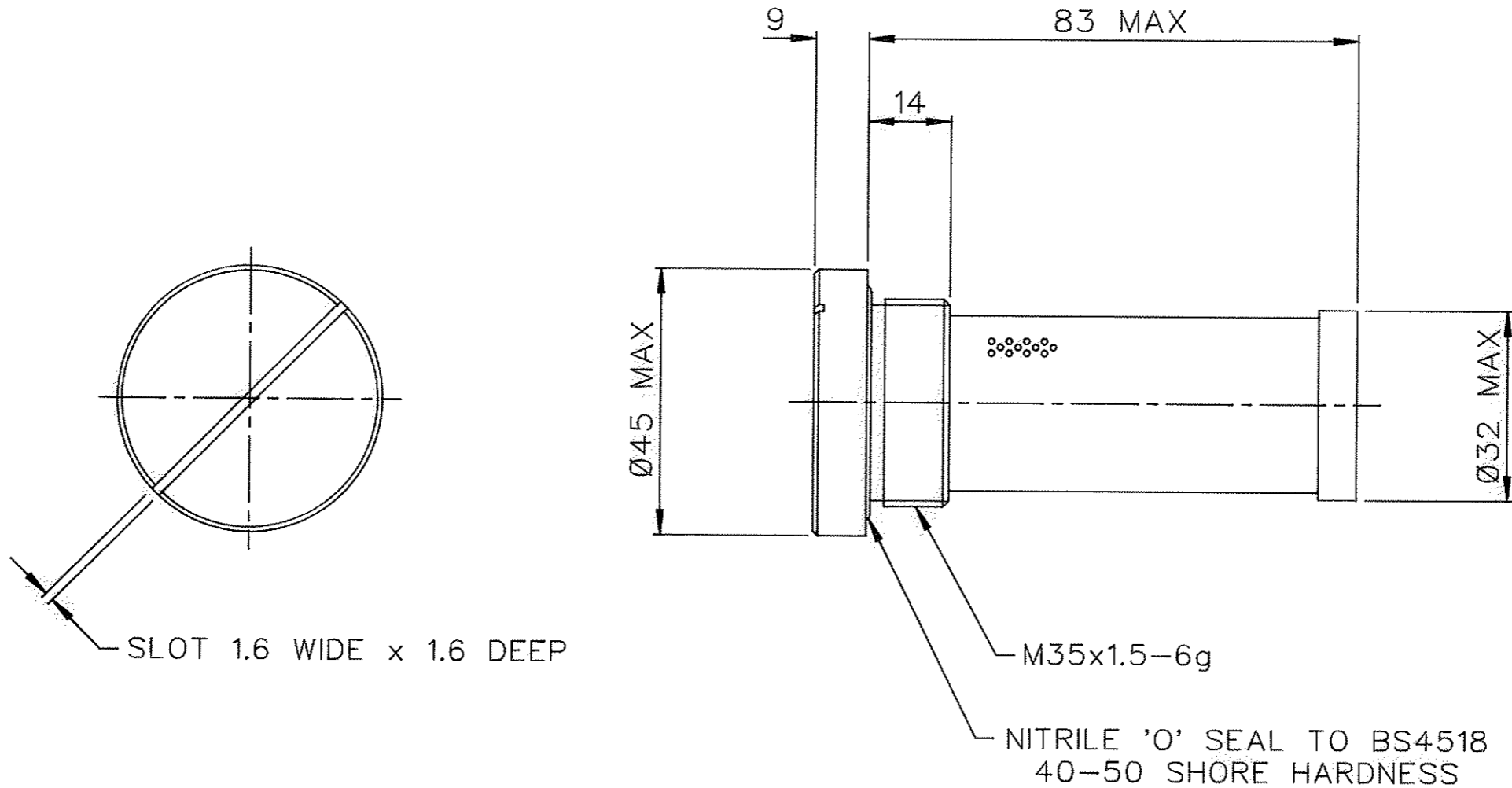
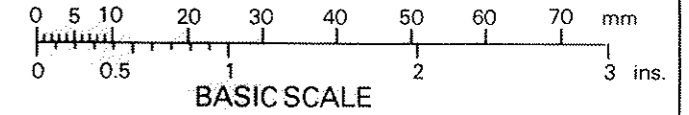

NOTES

1. CONTAINS MINIMUM 38 GRMS BEADED SILICA GEL DESICCANT SHALL CONFORM TO BS7554, 1-3mm BEAD SIZE.
2. DESICCANT CONTAINER DEHUMIDIFIER STATIC (DISPOSABLE) SHALL CONFORM TO DEF STAN 44-2 ALTHOUGH IT IS NOT A STANDARD RANGE ITEM.
3. PACKAGED FOR A 5 YEAR SHELF LIFE.

MATERIAL: ALUM ALLOY ANODISED TO DEF STAN 03-25
HEAD AND END CAP DYED BLACK, BODY DYED LIGHT METALLIC GREEN.

REDRAWN - NOTES CHANGED	5372	C	9/12/98
9 WAS 12	3582	B	16/12/88
		A	20/9/88
CHANGE	MOD. No.	ISSUE	DATE

MATERIAL	PROTECTIVE TREATMENT	TOLERANCES UNLESS STATED	±0.5	BROWNELL LTD. LONDON, N.W.10.		CUSTOMERS REF.	DRAWN	CHECKED
EST. WT.		DIMNS. IN mm/m.m.		TITLE			LJ	K
		SCALE (ORIGINAL)	1:1	DESICCANT CONTAINER DEHUMIDIFIER STATIC - LID (DISPOSABLE)		DRAWING No. BL/D 4967 INST		

THIS DESIGN IS THE PROPERTY OF BROWNELL LTD. AND MAY NOT BE COPIED OR REPRODUCED WITHOUT THEIR PRIOR WRITTEN PERMISSION.